

Photo © Jona Harnischmacher

CONTACT INFORMATION

Michael Zandl | Zellerstrasse 36 | 5671 Bruck/Glstr. | Austria
 +31 6 49226896 | +43 664 4060441
 info@michaelzandl.com | www.michaelzandl.com

IN SHORT

Duration: 60 min | Language: no words | Crew: 2 people | Age: 6+
 Stage: flat floor, minimum measurements: 8x6x3,7m (WxDxH)
 Possibility to completely darken the room
 Build-up time: 8 hours | max. 3 shows per day

FULL SHOW // Kristallwerk Graz | June 2019:

https://www.youtube.com/watch?v=ftceXVF_yrk&feature=youtu.be

TRAILER

https://www.youtube.com/watch?v=sQiK_qPp4sE&feature=youtu.be24

CREDITS

concept Michael Zandl
 director Matthias Romir
 artists Michael Zandl, Tom Henden
 dramaturgy Stefan Wipplinger
 technical assistance Daniel Beiter, Felix Gierlinger, Elias Wögerbauer
 special thanks to Roland Kumpl, Joanna Czekajlo, Melina
 Matzanke, Peter van Heesen, Kolja Huneck



TECHNICAL RIDER

THE PERFORMANCE Janus is a circus performance which is played indoors.

JANUS ARRIVES WITH 2 performers, 1 van (Renault Trafic, length: 5,4m)

DURATION The duration of the performance is **60 min**. In case of multiple shows per day a minimum of 3 hours between the beginnings of each show is needed. It is possible to play max. 3 shows per day.

STAGE DIMENSIONS The minimal floor dimensions for the stage are **8x6m** (width x depth) with a height of **3,7m** over the entire surface (free height under grid). In case of extra off-space left and right of the stage, it can be possible to play on smaller stages.

Please note that we have **two different possible sizes** of our stage:

Size A: 9x7x4,3m (WxDxH)

Size B: 8x6x3,7m (WxDxH)

FLOOR Janus is performed on **black dance-floor**. This dance-floor has to be arranged by the organization.

The floor has to be **levelled, firm, silent and flat**. It is essential that the floor is free of any irregularities and that it is **completely smooth** without any wrinkles, waves, overlaps, etc.. (we need to drive with a very small remote control car on it).

We have the possibility to bring our own dance-floor in certain cases (this has to be agreed on beforehand).

BLACKS It must be possible to **completely darken** the room (for blacks). All distracting lights (except emergency exits) must be turned off during the performance.

BUILD-UP & DOWN Time is needed to offload, build, break and load our decor and equipment. The required time depends on the situation, but we count with a minimum of 8 hours for build-up and 4 hours for build-down. Final times will always be discussed and agreed on with the organization.

We need help of one technician, which is familiar with the location, for the first 2 hours of our build-up. After that, one technician should be available at call if needed.

Any damage done to the property of the performers (equipment, car, etc..) which is caused by the staff of the organization, or any person hired by the organization, will be, without exception, fully covered by the organization.



-
- EQUIPMENT STORAGE** The contractor has to arrange a **lockable space** to store our equipment directly after arrival, until departure (in the same location as of the performance). We cannot leave our equipment in the car. The times of arrival and departure have to be agreed on beforehand. In case of an evening show, departure is the following day.
Required size: 3,5x2x2m (LxWxH)
- DECOR** We bring a **truss-construction** for our technical equipment, our curtains and part of our lights with us. In front of our structure we place two **side wings on tripods** (see technical drawings).
- SOUND** The contractor provides a sound installation. We need a connection to this sound installation on stage right side (audio jack 6,3mm left+right – for position on stage please have a look at the technical drawing – top view).
We will bring a second sound system, which is used only for sound effects on stage. In case the contractor cannot provide a sound installation, this system could be used for max. 150 spectators (this has to be discussed and agreed on beforehand).
- LIGHT** All required light equipment will be provided by us. We bring 16 LED Lamps (Cameo TS 60W). 2-3 Lamps have to be rigged in the location as front lights in a certain position. Please check the technical drawing carefully, to see if the required position is possible. In case of any concerns, please get in contact with us.
- LICENSING** All necessary licenses (e.g.: GEMA, music, events, etc..) will be organized and paid by the organizer.
- SMOKE MACHINE** We are using a smoke machine during the show and rehearsals/build-up. The organizer is responsible to take care of fire-alarms etc...
- AUDIENCE** To guarantee a good visibility of the show, the audience has to be seated in a certain position to the stage. Please have a look at the technical drawing.
- POWER SUPPLY** We need **two 230V 16 A power connections** for light and sound. For positions, please check technical drawing (top view).
- DRESSING ROOMS** A dressing room close to the stage is necessary. The dressing room must be warm and equipped with at least one mirror, running water, sufficient light and preferably a shower.



PARKING We will arrive with one van (Renault Trafic). For unloading and loading it must be possible to roll our equipment directly to the stage (and storage) on a wheel board.

Reservation of parking spaces and/or parking permits close to the performance-venue (max. 10 min walking) will be arranged by the organizer. Costs of parking on the days of the performance, build-up and build-down are on the account of the organization.

CATERING On performance days the organization will provide at least one warm meal for each performer, or pays each performer a per diem of 25€.

During our build-up, we expect water, tea, coffee and small snacks for 2 persons. NOTE! We are two vegetarians (no meat, no fish).

ACCOMODATION When performances are scheduled for multiple days in a row, or at times that make a build-up of build-down and travel unreasonable, the organization arranges and covers accommodation.

Rooms: 2 single rooms.



PLEASE NOTE THAT WE HAVE TWO DIFFERENT POSSIBLE SIZES OF OUR STAGE!

SIZE A: 9x7x4,3m / SIZE B: 8x6x3,7m

THE FOLLOWING DRAWINGS REFER ONLY TO SIZE A

PICTURE OF STAGE



TRUSS CONSTRUCTION

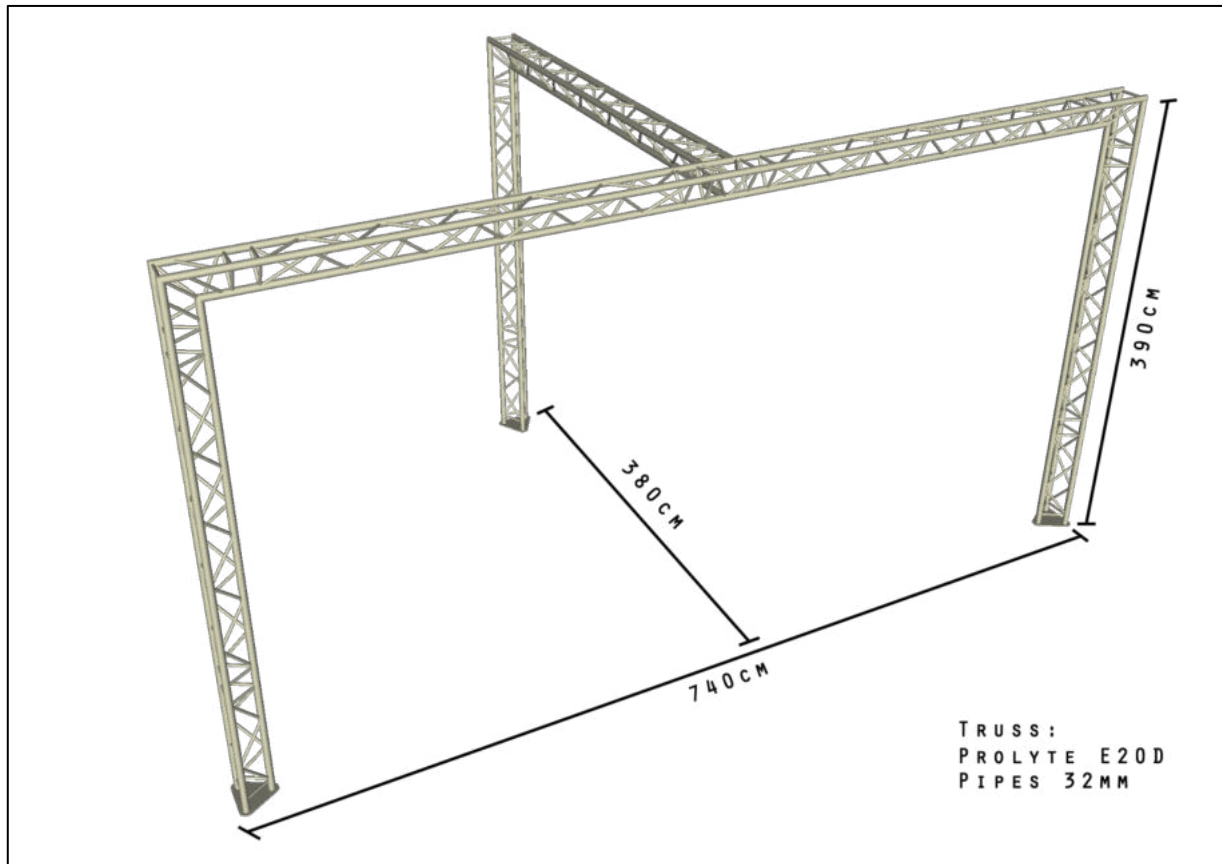

TOP VIEW

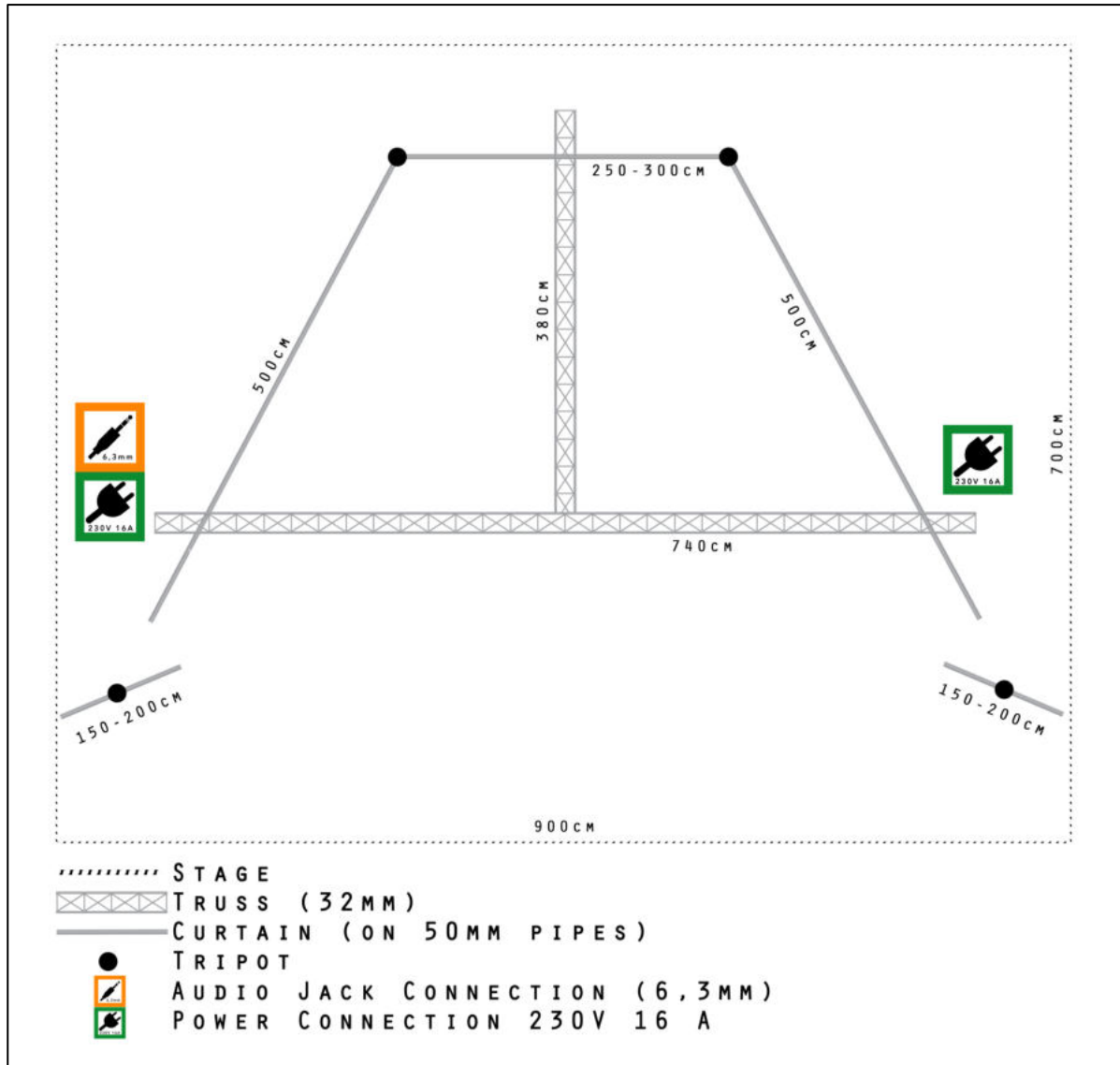

FRONTAL VIEW (without side wings)

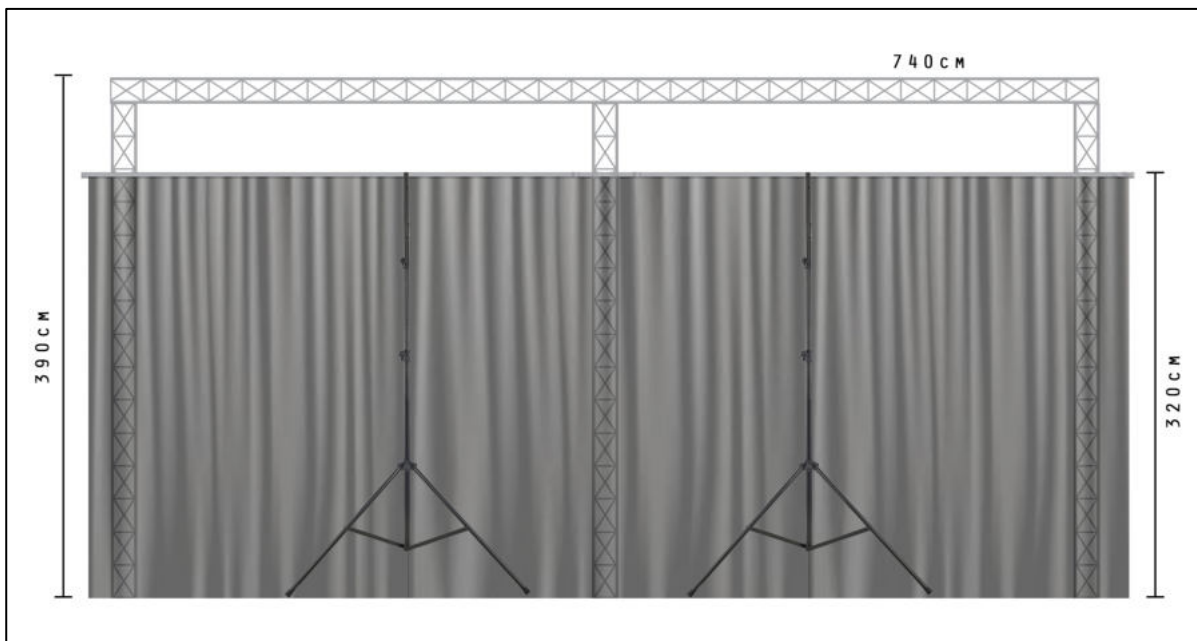

AUDIENCE (top view)

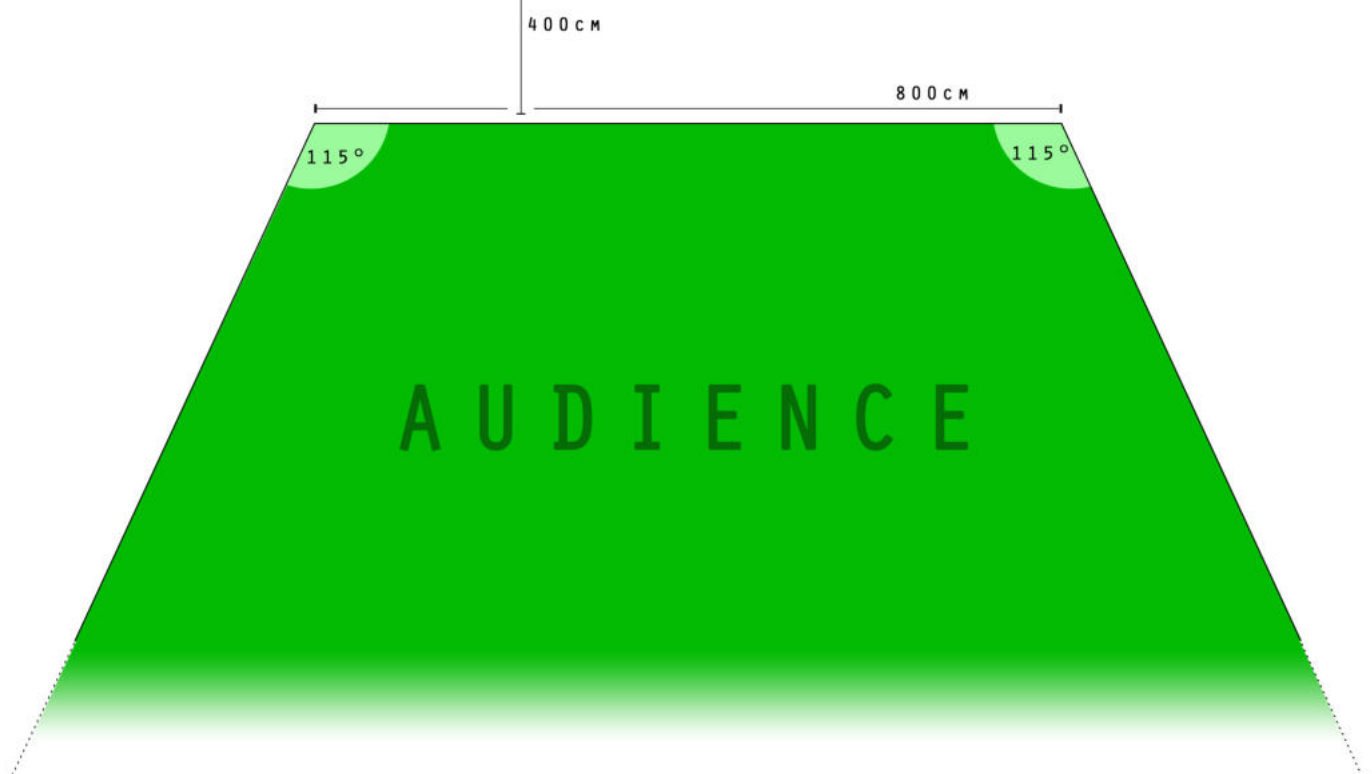
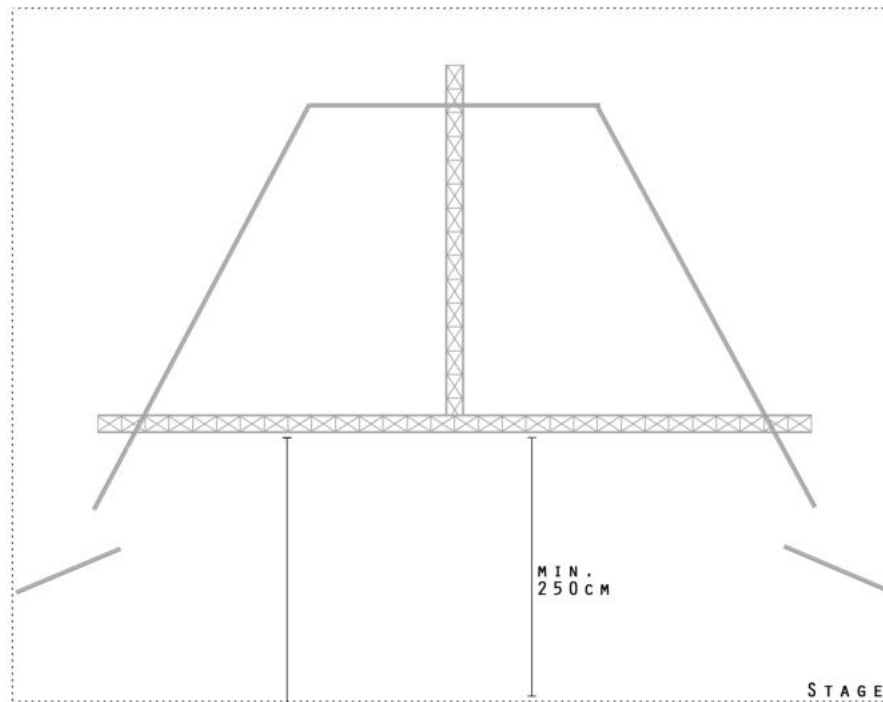

Max Audience Number: 300

Max Audience Height: 4m

This drawing describes the possible placement of the audience with a stage of 9x7m.

The angles of the possible audience area will become wider with a bigger stage.

If there are any uncertainties about the audience placement, please get in contact with us.

POSITION FOR FRONT LIGHT (top view)

